

easy-to-build Lazy Susan

Expand the capabilities of the finishing center with this handy turntable.



The problem with any finishing project is getting to all sides easily without having to handle the project. The solution is a simple lazy Susan turntable, like the one used in the finishing center (photo above).

The trick to installing a lazy Susan (photo below) is a little advance work. And that's just a matter of drilling a small access hole, as shown in the drawings at right.

To do this, center the lazy Susan on the turntable base, mark where the hole needs to be, and drill the hole (top drawing). Then screw the lazy Susan in place.

Now, flip this assembly over and set it in place on the top so it's centered. Finally, attach the lazy Susan to the top with screws using the access hole. 

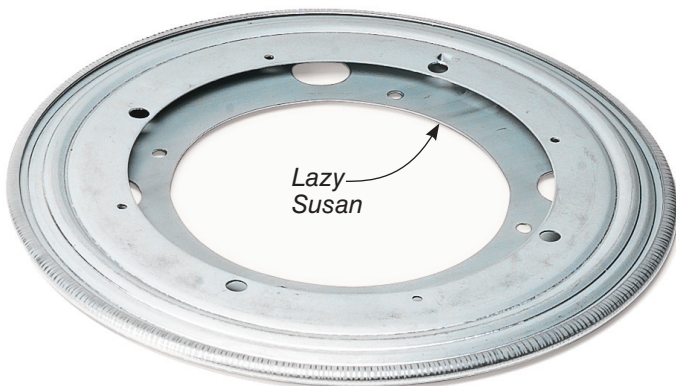

Base

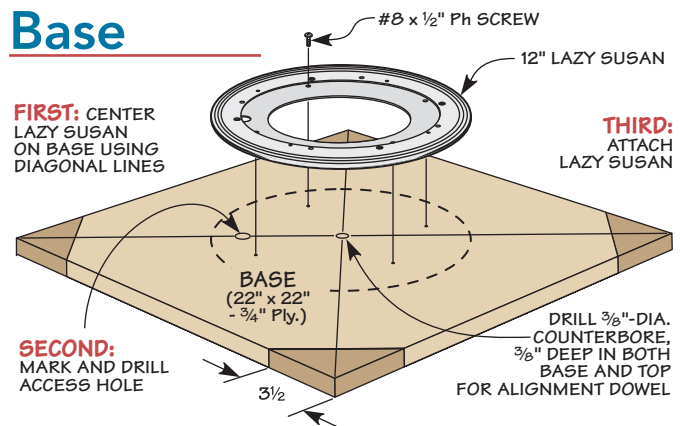

Top

