

taking a look at Doweling Jigs

■ On the next few pages, you'll see a number of doweling jigs you can use to create strong dowel joints (photo at right).

The standard accessories for each jig are shown along with some of the optional accessories available from the manufacturer. Note: Any accessories that are available but not shown are detailed in the text.

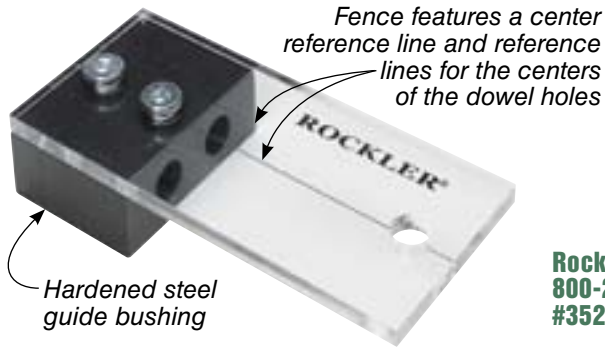

ROCKLER 3/8" DOWELING JIG

Simple and to the point, this jig from Rockler is designed to be clamped in place and used with a 3/8" drill bit and stop collar. Fine reference lines indicate both the center of each hole and the center of the pair and aid in aligning the jig.

Rockler
800-279-4441
#35242

TASK SELF-CENTERING JIG

The drill guide accepts replaceable bushings and automatically centers the bushings, and therefore the holes, on the workpiece as you tighten the jig in place. The fences travel along steel rods as you turn the crank.

The guide features four holes for guide bushings so you can center the dowel holes on spacings of 3/4", 1 1/4", 2", or 2 3/4". Three pairs of guide bushings are included (1/4", 5/16", and 3/8").

Guide bushing block self centers on every workpiece

Rockler
800-279-4441
#49221

Lee Valley
800-871-8158
#25K64.01

Viewing ports and reference lines on bushing block aid in workpiece alignment

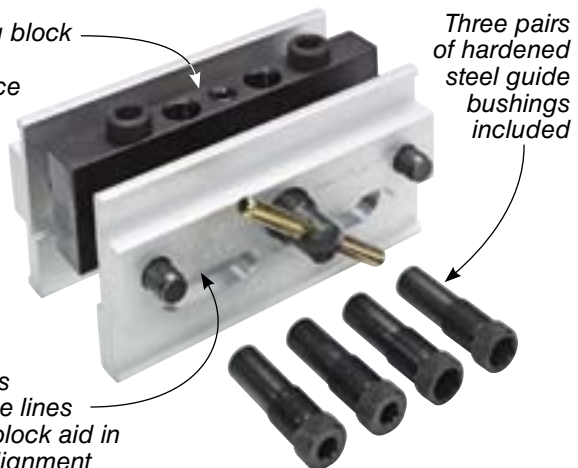

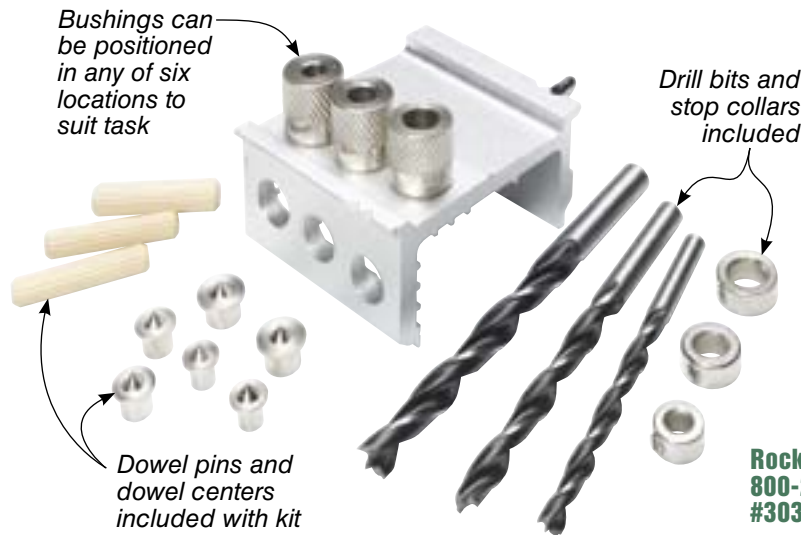

DOW'L SIMP'L KIT

The *Dowel Simp'l Kit* comes with a number of accessories, like three sizes of guide bushings, drill bits, dowel centers, stop collars, and a set of dowel pins.

Each guide bushing can be threaded into one of six locations depending on the thickness of the workpiece and the orientation of the joint.

Rockler
800-279-4441
#30345

GENERAL PRO DOWELING KIT

Like the *Simple Dowel Kit*, this model from *General* comes with three sizes of drill bits ($\frac{1}{4}$ ", $\frac{5}{16}$ ", and $\frac{3}{8}$ "), matching stop collars, dowel centers (in matching sizes plus an extra pair of $\frac{1}{2}$ " centers for good measure), and packages of dowel pins. They even throw in a small bottle of glue to get you started on assembling a joint.

You'll have to supply the drill bits and the stop collars for the $\frac{3}{16}$ ", $\frac{7}{16}$ ", and $\frac{1}{2}$ " holes in the guide.

Drilling guide can be positioned anywhere along guide rods and rotates for correct positioning

Available from
Amazon.com

NOTE:
All the accessories shown are included with kit

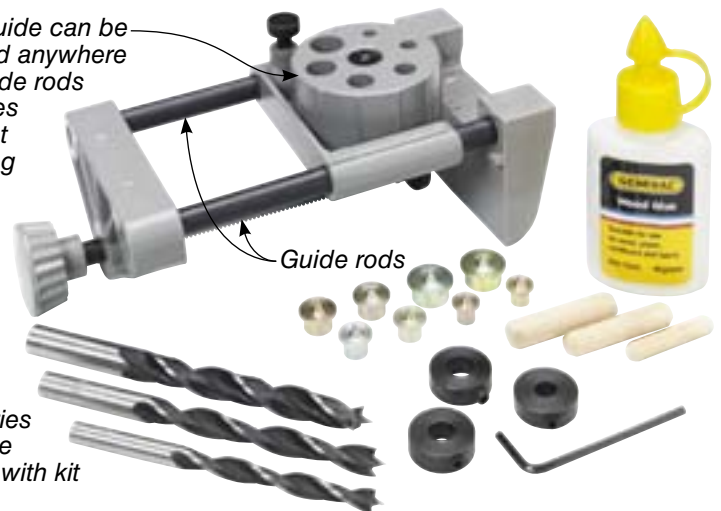

Guide bushings fit in carrier

Register pin accurately locates jig along workpiece

Optional gauge head positions jig accurately from one workpiece to another

Lee Valley
800-871-8158
#05J08.01

VERITAS DOWELING JIG

Based on the *Veritas 32mm Cabinet Making System*, this doweling jig is well-made and works with workpieces up to about $1\frac{1}{16}$ " thick. The basic jig comes with a bushing carrier, a register pin, and three hardened guide bushings ($\frac{1}{4}$ ", $\frac{5}{16}$ ", and $\frac{3}{8}$ ").

Optional accessories include a gauge head to accurately position the jig, a spare bushing carrier, and a spare register pin.

Metric bushings are available in sizes of 5, 6, 6.75, 7, 9, and 10mm. A $\frac{7}{32}$ " bushing and an unhardened bushing with a $\frac{3}{32}$ "-dia. hole that you can drill out to create a custom-size bushing are also available.

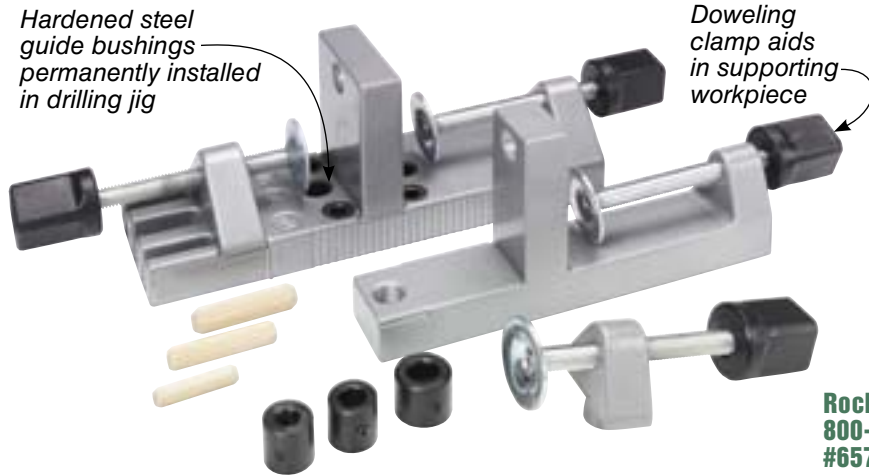

WOLFCRAFT DOWEL PRO KIT

The Wolcraft Dowel Pro allows you to drill the mating holes in two workpieces without a separate setup. For that reason, the jig comes with a drilling jig, a separate doweling clamp, three stop collars ($\frac{1}{4}$ ", $\frac{5}{16}$ ", and $\frac{3}{8}$ "), and a few dowel pins.

Rockler
800-279-4441
#65730

DOWELMAX PRECISION JOINERY SYSTEM

The Dowelmax includes everything you need for drilling $\frac{3}{8}$ " dowel joints. There are five $\frac{3}{8}$ " hardened steel bushings, a variety of spacers to customize the location of the dowels, a distance gauge and index pin for working with long pieces, an angle bracket for making T-joints, and a pair of drill bits with stop collars.

Optional accessories include a $\frac{1}{8}$ " spacer and a kit for $\frac{1}{4}$ " dowels.

Basic kit includes $\frac{3}{8}$ " bushings and a wide range of spacers for custom setups



Lee Valley
800-871-8158
25K64.10